

## IMPORTANT!

This equipment is intended to be used as a pipe surface scraper for electrofusion welding. It is designed for attachment on either service or mains pipe systems between 2" and 12" DR11.

This manual gives instructions on the correct assembly and safe use of your scraper. It is important that you read these instructions carefully, and keep these instructions for the life of the clamp.

This manual does not detail the specific welding procedure for the fittings: scraping, clamping and assembly of joints. For this information you must contact the manufacturer of the fittings.

Regularly check for obvious defects such as loose or damaged parts. Look for worn components and missing parts. There are no user serviceable parts on the scraper. It should be returned to an approved service agent for repair.

After use, clean the scraper with a soft brush or cloth.

Operating sizes:	2"-12" DR11 / 4"-10" DIPS
Operating temperature:	-40 °F to +122 °F
Cut Depth:	0.008"
Size:	16" x 8.25" x 6"
Weight:	13 lb



# HIGHLAND SCRAPER

2" to 12" DR11 pipes

4" to 10" DIPS pipes

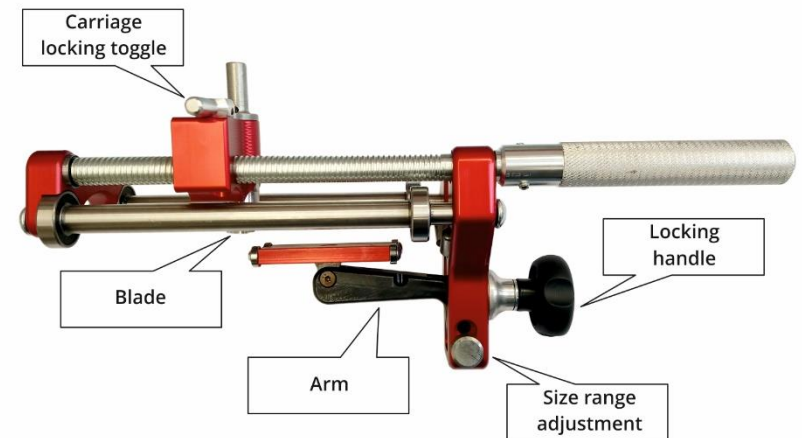

**1. Mark the scrape length.**

Hold the coupler against the end of the pipe and mark half the coupler length plus one inch. Draw a hatch pattern on the area to be scraped.



**2. Set tool size range.**

Remove the thumbscrew and position the arm to the correct range. Replace and tighten the thumbscrew.

Top = 2" to 8" (All DR sizes)  
Bottom = 4" to 12" (All DR sizes)

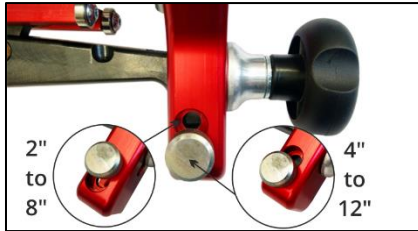

**3. Open tool arm.**

Unscrew the black locking handle counter clockwise to lower the arm.



**4. Place tool on pipe.**

Place the tool on to the end of the pipe so the arm fits inside the pipe.



**5. Set scrape length.**

Lift the locking toggle up and slide the carriage so the blade is in the correct scrape position. Push the locking toggle back down.



**6. Lock tool on pipe.**

Screw up the black locking handle clockwise to lift the arm inside the pipe and lock the tool on to the pipe wall.



**7. Scrape pipe.**

Rotate the tool clockwise around the pipe until the full surface of the pipe has scraped. A thin continuous ribbon of plastic will be removed.



**8. Remove tool.**

Unscrew the black locking handle counter clockwise to lower the arm, then remove the tool from the pipe.  
**DO NOT TOUCH THE SCRAPED SURFACE OF THE PIPE!**

