

# **HIGHLAND** MULTICLAMP

3" to 12" IPS pipes

4" to 10" DIPS pipes

---

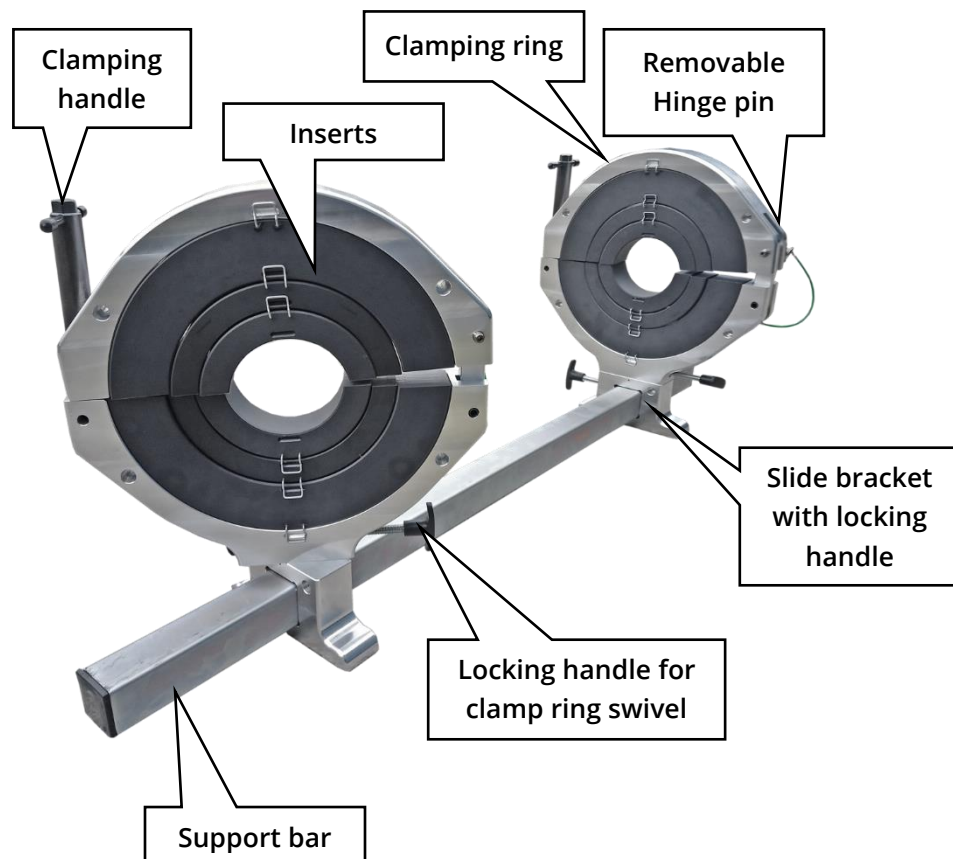

**Optional parts:**

HMC001	IPS Multiclamp Full Kit, 2-way: 4", 6", 8", 12" IPS
HMC002	IPS Multiclamp 3-way adapter: 4", 6", 8", 12" IPS
HMC003	3" IPS inserts, set of 4
HMC004	4" IPS inserts, set of 4
HMC005	6" IPS inserts, set of 4
HMC006	8" IPS inserts, set of 4
HMC007	10" IPS inserts, set of 4
HMC008#	DIPS Multiclamp Full Kit, 2-way: 4", 6", 8", 10" DIPS
HMC009#	DIPS Multiclamp 3-way adapter: 4", 6", 8", 10" DIPS
HMC010	4" DIPS inserts, set of 4
HMC011	6" DIPS inserts, set of 4
HMC012	8" DIPS inserts, set of 4
HMC013	10" DIPS inserts, set of 4

# The DIPS inserts nest into the 12" IPS clamping ring

## Clamp Configurations.

2 way  
Straight



2 way  
Elbow: 90°

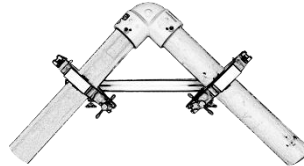

2 way  
Elbow: 45°

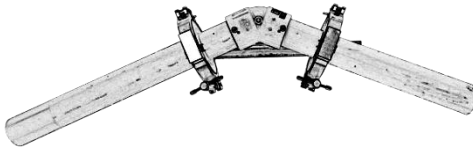

2 way  
Tee (socket sides)

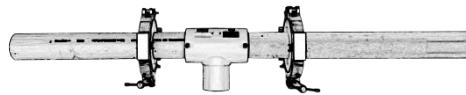

2 way  
Tee (spigot side)

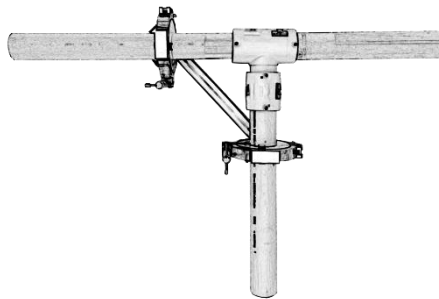

3 way  
Tee (all sides)

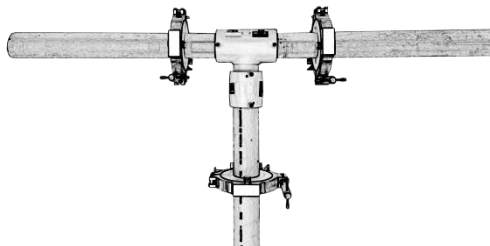

**Assemble the clamp ring.**

The two halves of the clamping ring can be separated with a removable hinge pin.

Assemble the ring by pushing the button in the center of the hinge pin and inserting the pin through the hinge.

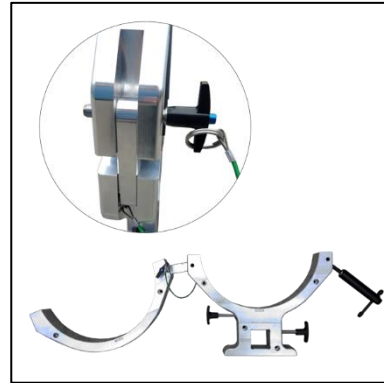

**Select insert sizes.**

Select the correct size of insert for the pipes being held. The inserts clip into each other, to remove them firmly push them sideways. Some sizes of pipe require multiple inserts.

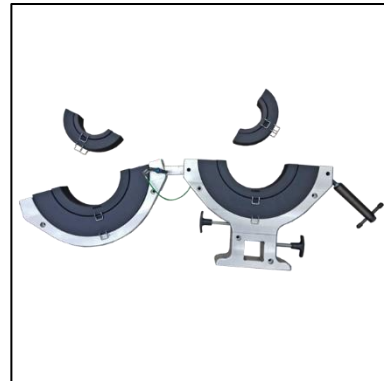

**Assemble the tool.**

Push the support bar through the slide brackets on each clamping ring and tighten the locking handle for the slide bracket when the correct position is reached.

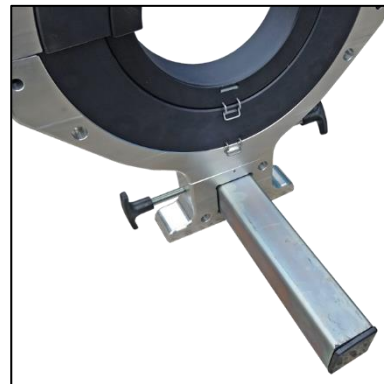

### **2-way Tool.**

The clamp rings should be positioned on the support bar, so they sit about four inches away from the edge of the fitting. This will provide good stability.

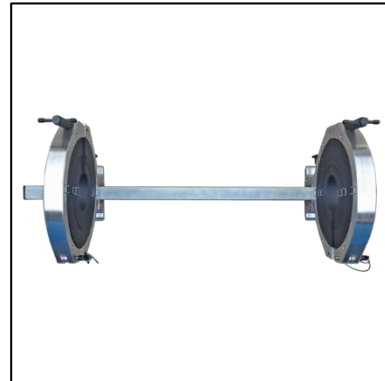

### **3-way Adapter.**

If using the 3-Way adapter, slide the third arm onto the support bar first, so that it sits in the middle. Tighten the silver locking handle to hold it steady. Now fit the clamping rings onto the support bar and tighten the locking handles for the slide brackets.

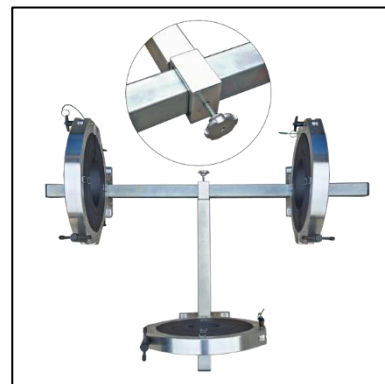

### **Select clamp angle.**

Slacken the black locking handle for the clamp ring swivel and rotate the clamping ring to the correct position. This has indents for 45 degree and 90 degree elbows.

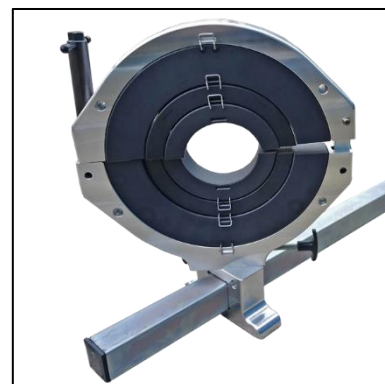

**Clamp pipe.**

Place the pipes and fitting into the clamp. Close the clamp rings and latch the clamping handle back into position. Tighten down the handle so it clamps and restrains the pipes.



**Weld fitting.**

Weld the electrofusion fitting as per the manufacturer's guidelines.

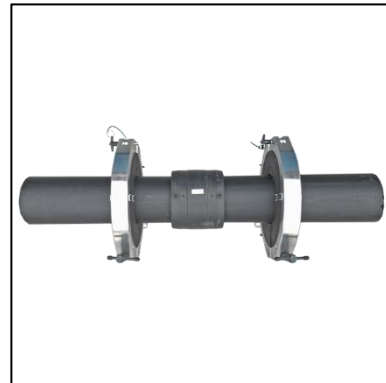

**Unclamp pipes.**

To unclamp the pipes, slacken the clamping handle and separate the clamping rings. The hinge pin can be removed if space is limited. Remove the tool from the pipe.



**IMPORTANT!**

This equipment is intended to be used as a restraining and re-rounding clamp for electrofusion welding. It is designed for service or main pipe lines incorporating electrofusion sockets, reducers and elbows, up to 12 inch diameter into them.

This manual gives instructions on the correct assembly and safe use of your clamp. It is important that you read these instructions carefully, and keep these instructions for the life of the clamp.

This manual does not detail the specific welding procedure for the fittings: scraping, clamping and assembly of joints. For this information you must contact the manufacturer of the fittings.

Regularly check for obvious defects such as loose or damaged parts. Look for worn components and missing parts. There are no user serviceable parts on the clamp. It should be returned to an approved service agent for repair.

After use, clean the clamp with a soft brush or cloth.

Operating sizes: 3", 4", 6", 8", 12" IPS or 4", 6", 8", 10" DIPS  
Operating temperature: -40 °F to +122 °F  
Size: 16" x 18½ " x 47"  
Weight: 56 lb

